

**Troubleshooting Chart:**

| Problem                        | Cause  | Solution   |
|--------------------------------|--|--|
| 1. No discharge                | a. No water<br>b. Magnetic valve not functioning<br>d. Eductor clogged<br>e. Clogged water inlet strainer  | a. Open water supply<br>b. Install valve parts kit<br>d. Clean* or replace<br>e. Disconnect inlet water line and clean strainer  |
| 2. No concentrate draw         | a. Clogged foot valve<br>b. Metering tip or eductor has scale build-up<br>c. Low water pressure<br><br>d. Discharge tube and/or flooding ring not in place<br><br>e. Concentrate container empty<br>f. Inlet hose barb not screwed into eductor tightly<br>g. Clogged water inlet strainer<br>h. Air leak in chemical pick-up tube | a. Clean or replace<br>b. Clean (descale)* or replace<br><br>c. Minimum 25 PSI (with water running) required to operate unit properly<br>d. Push tube firmly onto eductor discharge hose barb, or replace tube if it doesn't have a flooding ring.<br>e. Replace with full container<br>f. Tighten, but do not overtighten<br>g. Disconnect inlet water line and clean strainer<br>h. Put clamp on tube or replace tube if brittle |
| 3. Excess concentrate draw     | a. Metering tip not in place<br>b. Chemical above eductor  | a. Press correct tip firmly into barb on eductor<br>b. Place concentrate below the eductor   |
| 4. Failure of unit to turn off | a. Water valve parts dirty or defective<br>b. Magnet doesn't fully return<br>c. Push button stuck  | a. Clean* or replace with valve parts kit<br>b. Make sure magnet moves freely.<br>c. Remove button and clean cabinet/button to remove any dirt lodged in slide recess  |
| 5. Excess foaming in discharge | a. Air leak in pick-up tube  | a. Put clamp on tube or replace tube if brittle  |

\* In hard water areas, scale may form inside the discharge end of the eductor, as well as in other areas of the unit that are exposed to water. This scale may be removed by soaking the eductor in a descaling solution (deliming solution). To remove an eductor located in the cabinet, firmly grasp water valve and unthread eductor. Replace in same manner. Alternatively, a scaled eductor can be cleaned (or kept from scaling) by drawing the descaling solution through the unit. Operate the unit with the suction tube in the descaling solution. Operate the unit until solution is drawn consistently, then flush the unit by drawing clear water through it for a minute. Replace concentrate container and put suction tube into concentrate.



## Proportioner with (2) E-Gap Eductors

**Package Should Contain:**

1. Proportioner unit
2. Supply tubing
3. Discharge tubes for eductors
4. Mounting bracket & anchor kit
5. Metering tip kits
6. Instruction sheet

**THANK YOU FOR YOUR INTEREST IN OUR PRODUCTS**

Please use this equipment carefully and observe all warnings and cautions.

\*\*\*\*\*NOTE\*\*\*\*\*

|               |  |
|---------------|--|
| <b>WEAR</b>   | protective clothing and eyewear when dispensing chemicals or other materials or when working in the vicinity of all chemicals, filling or emptying equipment, or changing metering tips.   |
| <b>ALWAYS</b> | observe safety and handling instructions of the chemical manufacturer.<br><br>direct discharge away from you or other persons or into approved containers.<br><br>dispense cleaners and chemicals in accordance with manufacturer's instructions. Exercise CAUTION when maintaining your equipment.<br><br>reassemble equipment according to instruction procedures. Be sure all components are firmly screwed or latched into position. |
| <b>ATTACH</b> | only to tapwater outlets (85 PSI maximum)  |
| <b>KEEP</b>   | equipment clean to maintain proper operation.  |
| <b>NOTE</b>   | if the unit is used to fill a sink or discharge hose can be placed into a sink, the unit must be mounted so that the bottom of the cabinet is above the overflow rim of the sink.  |

**Installation and Operation:**

1. Find suitable place close to water source for unit. Remove dispenser cover by depressing the button on the top of the dispenser and pull the cover forward and off. Do not mount dispenser more than 6 feet (1.8 meters) above the bottom of the concentrate container, nor below the highest concentrate level (never mount your concentrate higher than the proportioner).
2. Remove mounting rail from the back of dispenser by rotating the black lock bars, located on the inside back of dispenser, rotate toward the outside of the dispenser.
3. Hold mounting rail level against wall and mark (2) mounting holes. Drill 9/32" hole and install anchors in wall. Secure mounting rail to wall with screws provided. NOTE: Distance from top of mounting rail to top of dispenser is 2.5". If mounting dispenser under cabinet or shelf be sure to leave clearance to access button at the top of dispenser for removal of cover.
4. Place the dispenser over the mounting rail aligning the bosses around the mounting screws with the large holes in the dispenser back. Rotate the locking tabs toward the center of the dispenser to secure the dispenser to the wall. **NOTE: IT IS REQUIRED THAT A SAFETY SCREW BE INSTALLED.** Mark the wall using one of the lower holes in the back of the dispenser. Remove the dispenser from the mounting rail by rotating locking tabs toward the outside of the dispenser then lifting the dispenser off of the mounting rail. Drill 9/32" hole and install anchor. Reattach the dispenser to the mounting rail (see #4). Install security screw through the back of the dispenser into anchor in the wall.
5. Select metering tips for the selector valve(s) or hosebarb. (see next two sections) Push each tip firmly into a separate hose barb extending from the selector valve. A tip with no hole (clear plastic) can be used to block any valve port being used. (this may be used for dispensing water only).
6. Cut supply tubing provided into separate supply tubes for each product to be dispensed. Supply tubes should reach from hose barb on eductor to bottom of concentrate container. Slide ceramic weight over one end of tube and slide a footvalve into the same end of the tube. (prepare a tube for each eductor.)
7. Slip other end of supply tube through an opening in either side of the cabinet and push over the hose barb/metering tip on the eductor. (Repeat for all eductors)
8. Place footvalve ends of supply tubes into concentrate containers. **REMEMBER TO CHECK FOOT VALVE STRAINERS PERIODICALLY FOR CLOGGING: CLEAN IF NECESSARY**
9. Connect water supply hose of at least 3/8"ID to water inlet swivel. (Minimum 25 PSI pressure, with water running, is required for proper operation.) Connect opposite end of hose to water supply. Turn water supply on.
10. A short discharge tube is used with the 1GPM eductor; minimum tube length is 8 inches (20cm) for proper operation. Longer tubes (6 feet) are used with a 3.5 GPM eductor. Do not remove the flooding rings from inside the tubes. Slide end of tube with flooding ring over eductor discharge outlet. (Repeat for all discharge outlets.) Hooks may be installed on longer tubes to allow discharge tube to conveniently hang from dispenser when not in use.
11. Replace dispenser cover. Hook two bottom latches, and swing up to snap over button on the top of dispenser.
12. To operate button fill units, depress button to dispense product, release button to stop flow. **IF YOU WISH TO BE ABLE TO LOCK THE BUTTON IN THE "ON" POSITION:** Depress button and slide button lock up, **TO UNLOCK, DEPRESS BUTTON AND RELEASE.**
13. Bottle fill activates by inserting a spray bottle over the discharge tube and lifting lever until flow starts. To stop flow, lower bottle off discharge tube. To operate units with remote bucket fill hold and depress lever of gun. To stop flow release lever. **IF YOU WISH TO BE ABLE TO LOCK THE REMOTE BUCKET FILL IN THE "ON" POSITION:** Depress lever and position lock on bottom of lever, **TO UNLOCK, DEPRESS LEVER AND RELEASE.**



A DOVER COMPANY

3798 Round Bottom Road, Cincinnati, OH 45244 U.S.A. • Phone: (513) 271-8800 • Fax: (513) 271-0160 • www.hydrosystemsco.com

10094397  
Rev. A 9/10

**Metering Tip Selection:**

The final concentration of the dispensed solution is related to both the size of the metering tip opening and the viscosity of the liquid being siphoned. For water-thin products, the chart at right can be used as a guideline. If product is noticeably thicker than water, consult the Measurement of Concentration Procedure below to achieve your desired water-to-product ratio. Because dilution can vary with water temperature and pressure, actual dilution achieved can only be ascertained by using the Measurement of Concentration Procedure. The clear, undrilled tip is provided to permit drilling to size not listed should you need a dilution ratio that falls between standard tip sizes.

**NOTE:** A 1 GPM eductor is grey; a 3.5 GPM eductor is yellow. Refer to parts diagram if unfamiliar with names of system components.

**Measurement of Concentration:**

You can determine the dispensed water-to-product ratio for any metering tip size and product viscosity. All that is required is to operate the primed dispenser for a minute or so and note two things: the amount of dispensed solution, and the amount of concentrate used in preparation of the solution dispensed. The water-to-product ratio is then calculated as follows:

Dilution Ratio (X:1) where X = Amount of Mixed Solution — Amount of Concentrate Drawn

Dilution Ratio, then, equals X parts water to one part concentrate (X:1). If the test does not yield the desired ratio, choose a different tip and repeat the test. Alternative methods to this test are 1) pH (using litmus paper), and 2) titration. Contact your concentrate supplier for further information on these alternative methods and the materials required to perform them.

| Tip Color | Orifice Size | Std. Drill Number | APPROXIMATE DILUTIONS<br>AT 40 PSI FOR WATER-THIN PRODUCTS (1.0 CP) |         |
|-----------|--------------|-------------------|---|---------|
|           |              |                   | Ratio (per Eductor Flow)  |         |
|           |              |                   | 1 GPM   | 3.5 GPM |
| No Tip    | .187         | (3/16)            | 2.6:1   | 4:1     |
| Grey      | .128         | (30)              | 2.6:1   | 4:1     |
| Black     | .098         | (40)              | 2.5:1   | 5:1     |
| Beige     | .070         | (50)              | 3:1   | 8:1     |
| Red       | .052         | (55)              | 5:1   | 13:1    |
| White     | .043         | (57)              | 7:1   | 22:1    |
| Blue      | .040         | (60)              | 9:1   | 26:1    |
| Tan       | .035         | (65)              | 11:1  | 34:1    |
| Green     | .028         | (70)              | 17:1  | 52:1    |
| Orange    | .025         | (72)              | 19:1  | 64:1    |
| Brown     | .023         | (74)              | 22:1  | 71:1    |
| Yellow    | .020         | (76)              | 32:1  | 102:1   |
| Aqua      | .018         | (77)              | 39:1  | 128:1   |
| Purple    | .014         | (79)              | 64:1  | 213:1   |
| Pink      | .010         | (87)              | 128:1   | 447:1   |

**MultiFlex Parts Diagram/List:**

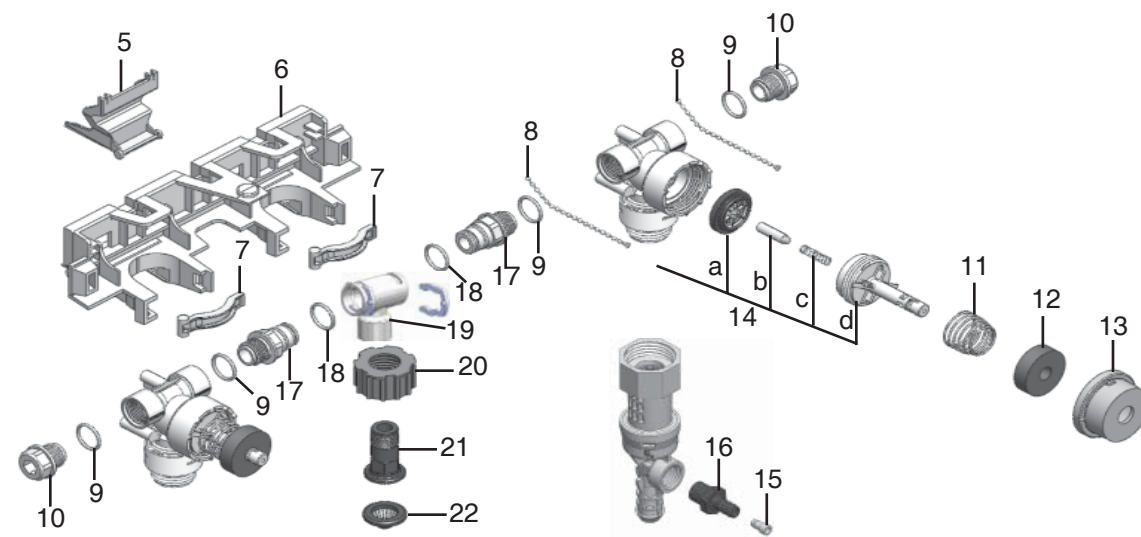

| Key  | Part No. | Description  |
|------|----------|--|
| 1    | 10094366 | Mounting Rail  |
| 2    | 10094358 | Connector, T-Rail  |
| 3    | 10094333 | Button   |
| 4    | 10094336 | Medallion, Select only                                   |
|      | 10094337 | Medallion, Button only                                   |
|      | 10094362 | Medallion, Button & Select                               |
|      | 10094373 | Medallion, Blank   |
| 5    | 10094342 | Bracket, upper pivot                                     |
| 6    | 10094352 | Bracket, valve, 2 button                                 |
| 7    | 10094341 | Lock Bar, valve bracket                                  |
| 8    | 90074612 | Ball Chain   |
| 9    | 10075950 | O-ring, EP, 016  |
| 10   | 10075926 | Pipe plug, 3/8 plastic                                   |
| 11   | 10079011 | Spring   |
| 12   | 10079000 | Magnet   |
| 13   | 10094383 | Cap, magnet  |
| 14   | 10075980 | Valve parts kit  |
|      |          | a. diaphragm   |
|      |          | b. armature  |
|      |          | c. spring  |
|      |          | d. valve bonnet  |
| 15   | 690014   | Metering tip kit   |
| 16   | 3041-R   | Hosebarb 1/4"  |
| 17   | 10094354 | Connector, stub  |
| 18   | 10094385 | O-ring, EP, 014  |
| 19   | 10094353 | Connector, Tee   |
|      | 10094348 | Clip, Tee connector                                      |
| 20   | 10082830 | Swivel collar  |
| 21   | 10082801 | Swivel stem  |
| 22   | 238100   | Strainer washer  |
| 23 a | 10094345 | 1.0 GPM eductor assembly                                 |
| b    | 10094346 | 3.5 GPM eductor assembly                                 |
| 24   | 10094319 | Select valve replacement kit                             |
| e    | 10088805 | Clip, E-Gap select                                       |
| f    | 329902   | O-ring   |
| g    | 10061430 | Suction inlet  |
| h    | 10094305 | Select valve   |
| 25a  | 10088839 | 1.0 GPM discharge tube with flooding ring (9")           |
| b    | 90080288 | 3.5 GPM discharge tube with flooding ring (6")           |
| c    | 10094320 | 3.5 GPM Remote gun discharge tube                        |
| 26   | 500814   | Tubing 1/4" x 14'  |
| 27   | 509900   | Weight   |
| 28   | 10089410 | Footvalve --Vtion (EPDM also available. Order 10076302.) |

**MultiFlex Parts Diagram:**

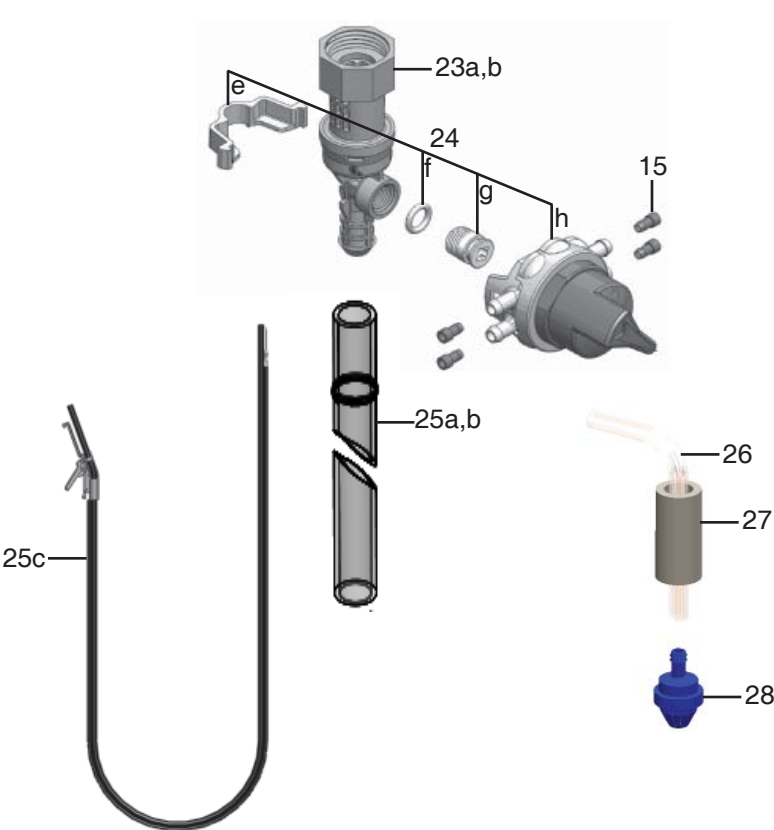
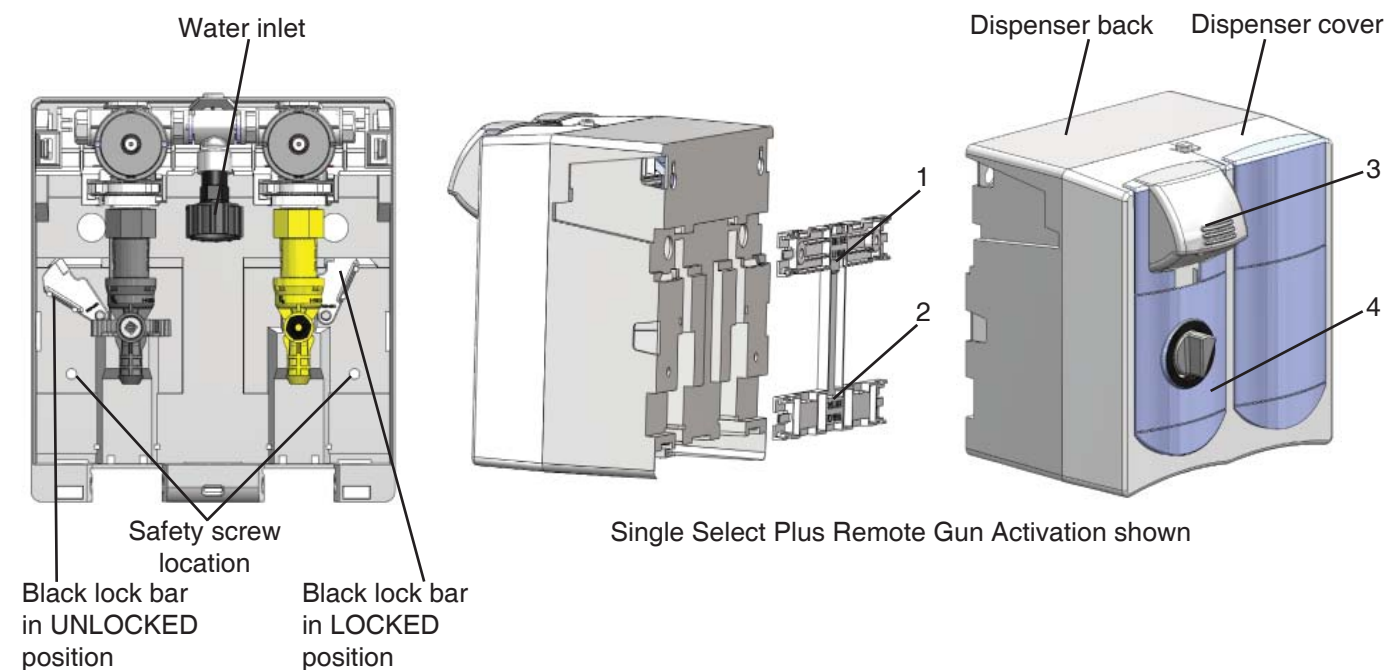

Single Select Plus Remote Gun Activation shown